

# Proportional directional spool valve type EDL

## Product documentation

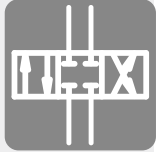

Series connection

Operating pressure  $p_{\max}$ :

320 bar

Flow rate  $V_{\max}$ :

48 lpm



© by HAWE Hydraulik SE.

The reproduction and distribution of this document as well as the use and communication of its contents to others without explicit authorisation is prohibited.

Offenders will be held liable for the payment of damages.

All rights reserved in the event of patent or utility model applications.

Brand names, product names and trademarks are not specifically indicated. In particular with regard to registered and protected names and trademarks, usage is subject to legal provisions.

HAWE Hydraulik respects these legal provisions in all cases.

Printing date / document generated on: 18.07.2018

# Contents

<b>1</b>	<b>Overview of proportional directional spool valve type EDL.....</b>	<b>4</b>
<b>2</b>	<b>Available versions, main data.....</b>	<b>5</b>
2.1	Order coding, overview.....	5
2.2	Connection blocks and end plates.....	6
2.2.1	Connection blocks.....	6
2.2.2	End plates.....	8
2.3	Valve section.....	9
2.3.1	Directional valve.....	9
2.3.2	Series intermediate plates.....	14
<b>3</b>	<b>Parameters.....</b>	<b>15</b>
3.1	General and hydraulic.....	15
3.2	Characteristics.....	17
3.3	Actuations.....	19
<b>4</b>	<b>Dimensions.....</b>	<b>21</b>
4.1	Connection blocks.....	21
4.2	Valve sections.....	23
<b>5</b>	<b>Assembly, operation and maintenance recommendations.....</b>	<b>26</b>
5.1	Intended use.....	26
5.2	Note regarding assembly, installation and conversion.....	27
5.2.1	Mounting.....	27
5.2.2	Piping.....	27
5.2.3	Seal kits.....	27
5.3	Operating instructions.....	28
5.4	Maintenance information.....	28
<b>6</b>	<b>Other information.....</b>	<b>29</b>
6.1	Notes for selection and lay-out.....	29
6.2	Circuit examples.....	31

Proportional directional spool valves are a type of directional valve. They control the direction of movement and the velocity of individual or multiple hydraulic consumers actuated simultaneously. Control is independent of the load and continuous.

The directional spool valve type EDL with series connection is actuated directly. The flow rates for the individual consumers can be individually adjusted. The proportional directional spool valve can be flexibly adapted to different control tasks by means of additional functions in the intermediate plates and ancillary blocks.

The directional spool valve type EDL can be combined directly with the proportional directional spool valve type PSL and PSV in size 2 and is therefore suitable for constant and variable pump systems. It is used in mobile hydraulics, in particular in civil engineering and agricultural engineering.

**Features and benefits:**

- One valve for different control functions and small flow quantities
- Energy-saving closed-centre systems
- Compact and lightweight design
- Modular system can be directly combined with type PSL/PSV-2

**Intended applications:**

- Construction and construction materials machinery
- Cranes and lifting equipment
- Machines for forestry and agricultural purposes
- Municipal trucks

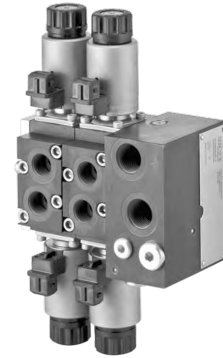

*Proportional directional spool valve type EDL*

## 2 Available versions, main data

### 2.1 Order coding, overview

Order coding example:

PSV 3X	B6	-2	-DA -DA	2 2	L H	25/16 40/25	C ... X	W3	/E /EI	/2 /2 AN300 BN350	-E0	-G 24	
													<b>Solenoid voltage</b> Table 11 Solenoid voltage and solenoid version
													<b>End plates</b> Table 3 End plates
													<b>Ancillary blocks</b> Table 12 Ancillary blocks (selection) Table 12a Intermediate plates (selection)
													<b>Actuation types</b> Table 10 Actuation types
													<b>Shuttle valve</b> Table 9 Shuttle valve
													<b>LS pressure limitation</b> Table 8 LS pressure limitation
													<b>Flow rates</b> Table 7 Maximum flow rates P → A(B) Table 7a Combination of flow rates
													<b>Circuit symbols</b> Table 6 Circuit symbols
													<b>Inflow controller</b> Table 5 Inflow controller
													<b>Directional valve, basic block</b> Table 4 Basic block
													<b>Size</b>
													<b>Additional elements</b> Table 2 Additional elements
													<b>Connection blocks</b> Table 1 Connection blocks

A maximum of 10 directional spool valves can be switched in series in one or more valve manifold(s) via the internal LS line. If more are required, external wiring must be provided (see note in [Chapter 6, "Other information"](#) ("Combination of more than 10 directional spool valves")).

## 2.2 Connection blocks and end plates

There are the following basic variants of connection blocks:

- Connection blocks with integrated 3-way controller when using a constant pump system (open centre) – type PSL
- Connection blocks for use with variable pump systems (closed centre), constant pressure systems or for parallel oil supply of multiple physically separate directional spool valve banks in the second and all further valve blocks – type PSV
- Adapter plates for combining proportional directional spool valves type PSL and PSV, size 3 and 5

Order coding of a single connection block (example):

PSV 3X - 2



### Note

The size specification is essential. Here: -2

### 2.2.1 Connection blocks

Order coding example:

PSV 3X | B . | - 2 | -...- E1

Size

Additional element Table 2 Additional elements

Connection blocks Table 1 Connection blocks

**Table 1 Connection blocks**

Coding	Port	Description
PSV 3X-2	G 1/2 (BSPP)	Connection blocks for variable pump
PSV 3X B.-2	G 1/2 (BSPP)	Connection blocks for variable pump with orifice additional element, see Table 2
PSV E0	--	Initial plate without separate ports. Can only be used in combination with the middle input block ZPL 22 P6R6, see <a href="#">Chapter 2.3.2, "Series intermediate plates"</a> <b>Operating pressure max = 250 bar!</b>
PSL 3 ..	G 1/2 (BSPP)	Connection blocks for constant pumps, (see <a href="#">D 7700-2</a> )
PSL UNF 2..	SAE-8 (3/4-16 UNF-2B)	
PSV 3 ..	G 1/2 (BSPP)	Connection blocks for variable pump, (see <a href="#">D 7700-2</a> )
PSV UNF 2..	3/4-16 UNF-2B	
ZPL 32	--	Adapter plate for combining proportional directional spool valve type PSL and PSV size 3 (see <a href="#">D 7700-3</a> ) or size 5 (see <a href="#">D 7700-5</a> )
ZPL 52	--	

## Circuit symbols

PSV 3X-2



PSV 3X B.-2



PSV E0-2



**Table 2 Additional elements**

(For notes and explanation, see [Chapter 6, "Other information"](#) ("On connection blocks"))  
 Additional elements only suitable where variable pumps are used (limitation of the control oil flow).

Coding	Description
No designation	Standard, without additional element
B 4, B 5, B 6, B 7, B 8	Orifice $\varnothing$ 0.4 mm, 0.5 mm, 0.6 mm, 0.7 mm or 0.8 mm in the LS gallery (for control oil limitation)

## 2.2.2 End plates

Order coding example:

PSV 3 X - 2 - DA 2 L25/25/E/2 - **E 0** - G 24

End plates Table 3 End plates

### Table 3 End plates

Coding	Port	Description	Circuit symbol
<b>E 0</b>	--	End plate without additional function, not in combination with valve sections SL2, SL3 or SL5 <ul style="list-style-type: none"> <li>• Can only be used with max. three sections</li> <li>• Only in conjunction with shuttle valve, coding W 3, Table 9 in last valve section</li> </ul> <p><b>Operating pressure max = 250 bar!</b></p>	
<b>E 1</b> <b>E 1 UNF</b>	G 1/4 (BSPP) SAE-4 (7/16-20 UNF-2B)	With control oil return line T external to tank	
<b>E 2</b> <b>E 2 UNF</b>	G 1/4 (BSPP) SAE-4 (7/16-20 UNF-2B)	Like E 1, with additional port Y for connection to the LS outlet of another, separately arranged PSV spool block	
<b>E 4</b> <b>E 4 UNF</b>	G 1/4 (BSPP) SAE-4 (7/16-20 UNF-2B)	Like E 1, however control oil return line is internal, maximum return pressure of 10 bar!	
<b>E 5</b> <b>E 5 UNF</b>	G 1/4 (BSPP) SAE-4 (7/16-20 UNF-2B)	Like E 2, however control oil return line is internal, maximum return pressure of 10 bar!	

**i** Note

- Details for end plates E 1, E 1 UNF, E 2, E 2 UNF, E 4, E 4 UNF, E 5, E 5 UNF see [D 7700-2](#)
- All end plates of the proportional directional spool valve type PSL and PSV size 2 can be used (see [D 7700-2](#))





**Table 4 Basic block**

Coding	Description
DA	Complete valve section with an ancillary block in accordance with Table 12 <a href="#">D 7700-2</a>

**Circuit symbol**

With respect to main flow and actuation, the circuit symbols are neutral and must be supplemented by the corresponding circuit symbols given according to Table 6 to 10, Chapter 6, see also examples in Table 10

4/3-way directional spool valve with inflow controller  
 Example: - DA 7 H40/40/E/2 (-DT 12)

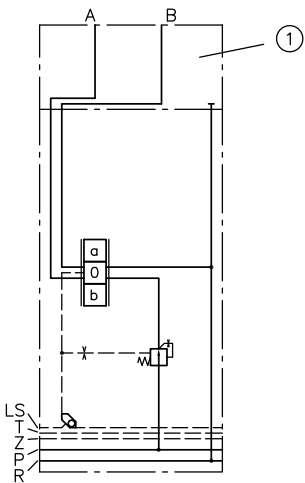

4/3-way directional spool valve with inflow controller and LS pressure limitation  
 Example: - DA 2 L25/16 C 200 /E/2 (- X 24)

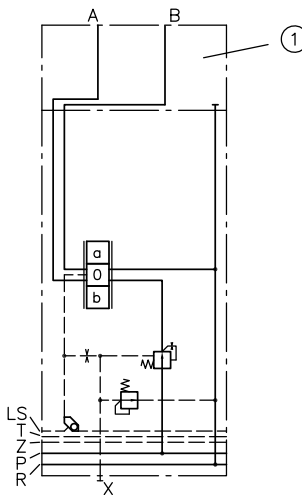

1 Ancillary block and intermediate block acc. to [D 7700-2](#)

**Table 5 Inflow controller**

Coding	Description
2	<b>Standard</b> , with inflow controller, for simultaneous load-compensated moving of several consumers (4/3-way directional spool valve, standard version, control pressure approx. 5 bar)
7	With inflow controller (for circuit symbol, see coding 2) but with reinforced 2-way control spring (control pressure approx. 9 bar). Only usable in conjunction with connection blocks type PSV or the middle input block type ZPL 22 P6R6, see <a href="#">Chapter 6, "Other information"</a>
R 2 R 7	Like coding 2, 7 but with additional check valve function (spool valve = slight leakage) Only usable in conjunction with connection blocks type PSL.H../... (only DA R 2) or type PSV or the middle input block type ZPL 22 P6R6, see <a href="#">Chapter 6, "Other information"</a>

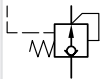

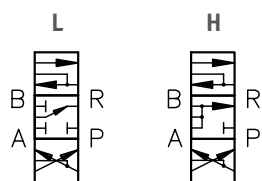
**Table 6 Circuit symbols**

**Table 7 Maximum flow rates P → A(B) in accordance with coding**

Coding for spool valve acc. to Table 6	Coding for flow rate $Q_{A, B}$ (lpm) at consumer ports A and B					
	3	6	10	16	25	40
2	3	6	10	16	25	40
7	4	7	12	19	29	48

**Note**

- The specified nominal flow rates correspond to the set values for E actuation. For EI actuation, the max. flow rates can be higher.
- The maximum reflux flow rate must not exceed 80 lpm.
- The flow rates for the consumer ports A and B can be selected in accordance with Table 7a, e.g. 40/25, 16/16. This enables optimal adaptation to the respective consumer while exploiting the full functional lift. In addition, there is the possibility of stroke limitation.

**Table 7a Combination of flow rates**

Coding L		Consumer port B					
		3	6	10	16	25	40
Consumer port A	3	●	●				
	6	●	●		●		
	10		●	●	●		
	16				●	●	
	25				●	●	●
	40					●	●

Coding H		Consumer port B					
		3	6	10	16	25	40
Consumer port A	3	●					
	6		●				
	10		●	●			
	16			●	●		●
	25					●	●
	40			●		●	●

**Table 8 LS pressure limitation**

Coding	Description	Circuit symbol
No designation	Without protection	--
C ... X	Joint LS pressure limitation for A and B with pressure specification and load pressure, signal output G 1/8 (BSPP), only in conjunction with solenoid version coding AMP.. and DT.. (Table 11)	

Order coding example:

DA 2 L 25/16    **W 3**    /E/2 - G24

Shuttle valve    Table 9 Shuttle valve

**Table 9 Shuttle valve**

Coding	Description	Circuit symbol
No designation	Shuttle valve in LS gallery	
W 3	Without shuttle valve, e.g. in last valve section for combination with end plate coding E 0	

**Table 10 Actuation types**

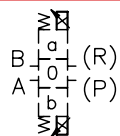
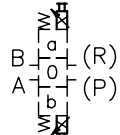
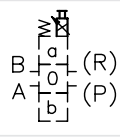
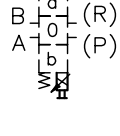
Coding	Description	Circuit symbol
<b>E</b>	Electrical actuation with stroke limitation	
<b>EI</b>	Electrical actuation with manual override	
<b>AEI</b>	Electrical actuation with manual override, A-side only	
<b>BEI</b>	Electrical actuation with manual override, B-side only	

 **Note**

- For reference values for start of flow at A or B (= min.) up to max. usable volume flow in accordance with Table 7, see [Chapter 3.2, "Characteristics"](#)
- The solenoid voltage and solenoid version are defined at the end of the type designation and applies to all solenoids in the valve bank, see Table 11

**Table 11 Solenoid voltage and solenoid version**

Coding	Electrical connection	Nominal voltage	Protection class (IEC 60529)
<b>X 12</b> <b>X 24</b>	DIN EN 175 301-803 A (Coding G.. with line connector, coding L.. with LED plug)	12 V DC 24 V DC	IP 65
<b>AMP 12</b> <b>AMP 24</b>	AMP Junior Timer	12 V DC 24 V DC	IP 65
<b>DT 12</b> <b>DT 24</b>	DEUTSCH (DT 04-2P)	12 V DC 24 V DC	IP 69 K

The EDL valve sections can be freely combined with all ancillary blocks and intermediate plates (parallel connection) type PSL and PSV, size 2. For a detailed overview of the available variants, see [D 7700-2](#)

**Table 12 Ancillary blocks (selection)**

Coding	Port	Description
/2 /3 /UNF 2	G 3/8 (BSPP) G 1/2 (BSPP) SAE-...	Ancillary blocks without additional functions
/2 AS.. BS..	G 3/8 (BSPP)	Ancillary blocks with shock valves at A and B (mutual spraying), with pressure specification (bar)
/2 AN... BN... /UNF 2 AN.. BN..	G 3/8 (BSPP) SAE	Ancillary blocks with shock and servo-suction valves at A and B, with pressure specification (bar)
/2 AL.. BL.. /UNF 2 AL.. BL..		Ancillary blocks with load-holding valves at A and B, with pressure specification (bar)

**Table 12a Intermediate plates (selection)**

Coding	Description
/ZDR /ZDS	Short-circuit valve between A and B
/ZAL.. BL..	Intermediate plates with load-holding valves at A and B, with pressure specification (bar)
/ZDRH	Intermediate plates with releasable check valves
/Z 40	Spacer plate



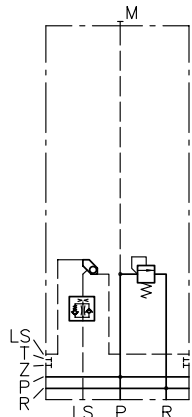

### 2.3.2 Series intermediate plates

Coding	Port (ISO 228-1) (BSPP) P, R	Description	Circuit symbol
ZPL 22 P6R6	G 1 1/4	Middle input block for installation of EDL 2 sections on both sides. Hydraulic oil supply via variable pump with load-sensing controller, as 2nd separate block or for constant pressure systems. Only possible in combination with initial plate PSV E0 - 2 (see <a href="#">Chapter 2.2.1, "Connection blocks"</a> , Table 1)	

## 3 Parameters

### 3.1 General and hydraulic

#### General information

<b>Description</b>	Proportional directional spool valve EDL																			
<b>Design</b>	Spool valve, valve bank, up to 10 valve sections, all-steel version																			
<b>Material</b>	Steel; nitrided valve housing, hardened and ground functional inner parts Surface treatment (solenoid): DIN 50979-Fe ZnNi 8																			
<b>Mounting</b>	Valve bank M8, see <a href="#">Chapter 4, "Dimensions"</a>																			
<b>Installation position</b>	As desired																			
<b>Ports</b>	<table border="1"> <tr> <td><b>P</b></td> <td>Hydraulic oil inlets (pump) or lead-on</td> </tr> <tr> <td><b>R</b></td> <td>Return lines</td> </tr> <tr> <td><b>A, B</b></td> <td>Consumer ports</td> </tr> <tr> <td><b>LS</b></td> <td>Load-signal outlet, e.g. port for pump controller on PSV</td> </tr> <tr> <td colspan="2"> <div style="border: 1px solid black; padding: 5px;">  <b>Note</b> No pressure inlet. </div> </td> </tr> <tr> <td><b>M</b></td> <td>Pressure gauge port (pump side)</td> </tr> <tr> <td><b>Z</b></td> <td>Pilot pressure connection (inlet: 20...40 bar; outlet: 20 or 40 bar)</td> </tr> <tr> <td><b>T</b></td> <td>Control oil tank line</td> </tr> <tr> <td><b>Y</b></td> <td>Load-signal inlet (end plates E 2, E 5, E 18, E 18 UNF, E 20 and E 20 UNF)</td> </tr> </table>	<b>P</b>	Hydraulic oil inlets (pump) or lead-on	<b>R</b>	Return lines	<b>A, B</b>	Consumer ports	<b>LS</b>	Load-signal outlet, e.g. port for pump controller on PSV	<div style="border: 1px solid black; padding: 5px;">  <b>Note</b> No pressure inlet. </div>		<b>M</b>	Pressure gauge port (pump side)	<b>Z</b>	Pilot pressure connection (inlet: 20...40 bar; outlet: 20 or 40 bar)	<b>T</b>	Control oil tank line	<b>Y</b>	Load-signal inlet (end plates E 2, E 5, E 18, E 18 UNF, E 20 and E 20 UNF)	
<b>P</b>	Hydraulic oil inlets (pump) or lead-on																			
<b>R</b>	Return lines																			
<b>A, B</b>	Consumer ports																			
<b>LS</b>	Load-signal outlet, e.g. port for pump controller on PSV																			
<div style="border: 1px solid black; padding: 5px;">  <b>Note</b> No pressure inlet. </div>																				
<b>M</b>	Pressure gauge port (pump side)																			
<b>Z</b>	Pilot pressure connection (inlet: 20...40 bar; outlet: 20 or 40 bar)																			
<b>T</b>	Control oil tank line																			
<b>Y</b>	Load-signal inlet (end plates E 2, E 5, E 18, E 18 UNF, E 20 and E 20 UNF)																			
<b>Hydraulic fluid</b>	Hydraulic oil: according to part 1 to 3; ISO VG 10 to 68 according to DIN ISO 3448 Viscosity limits: min. approx. 4, max. approx. 1500 mm <sup>2</sup> /s opt. operation approx. 10... 500 mm <sup>2</sup> /s. Also suitable for biologically degradable hydraulic fluids type HEPG (polyalkylene glycol) and HEES (synthetic ester) at operating temperatures up to approx. +70°C.																			
<b>Recommended cleanliness level</b>	<b>ISO 4406</b> <hr style="width: 50%; margin-left: 0;"/> 20/17/14...18/15/12																			
<b>Temperatures</b>	Environment: -40 ... +50°C, oil: -25 ... +80°C, pay attention to the viscosity range. Start temperature: down to -40°C is permissible (observe start viscosities!), as long as the steady-state temperature is at least 20K higher for subsequent operation. Biologically degradable pressure fluids: Note manufacturer specifications. With consideration for the seal compatibility, not above +70°C.																			
	<div style="border: 1px solid black; padding: 5px;">  <b>Note</b> Note restrictions on explosion-proof solenoid. </div>																			

## Pressure and volumetric flow

### Operating pressure

- $p_{\max} = 320$  bar; ports P, A, B, LS, M, Y
- The pressure achievable at the consumer side of the directional spool valves is lower by the amount of the internal control pressure drop at the 3-way controller PSL (see characteristic curve) or at the pump controller (PSV).
- Return connection R(R1)  $\leq 50$  bar

### Volumetric flow

Max. consumer flow rates accordingly, see [Chapter 2.3.1, "Directional valve"](#), Table 7

## Weight

### Connection block

#### Type

PSV 3X-2, PSV 3X.-2 = 1.7 kg

PSV E0-2 = 0.3 kg

For other connection blocks, see [D 7700-2](#)

### Valve section

DA.. E, EI = 2.5 kg

DA.. AE, AEI, BE, BEI = 1.9 kg

For other ancillary blocks, see [D 7700-2](#)

### End plate

(EDL 2-) E 0 = 0.3 kg

For other end plates, see [D 7700-2](#)



### 3.2 Characteristics

Oil viscosity approx. 60 mm<sup>2</sup>/s

$\Delta p$ -Q characteristic curves

Pressure-limiting valve in the middle input  
block type ZPL 22 P6R6

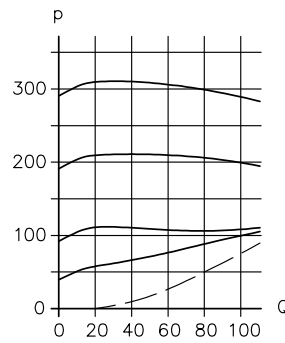

Q flow rate (lpm); p pressure setting (bar)

Directional spool valve  
P→A(B), A(B)→R

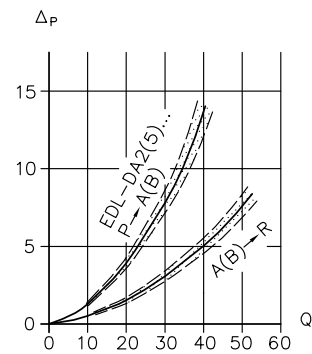

2-way inflow controller

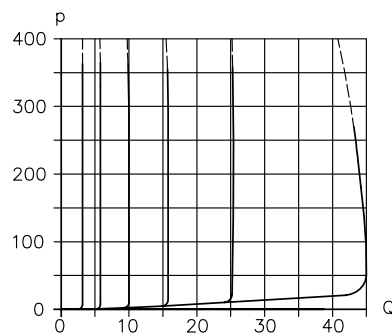

Q flow rate (lpm); p load pressure (bar)

LS pressure limitation coding C ...

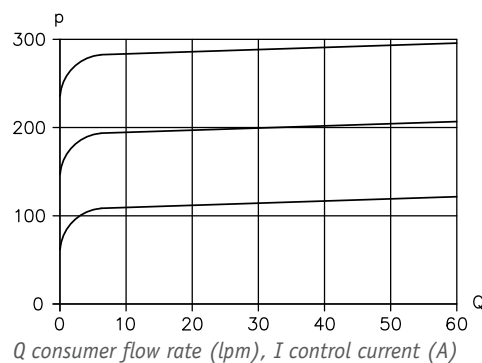

Q consumer flow rate (lpm), I control current (A)

Control characteristic curve for consumer flow rate  
(reference values, example for directional spool valve variant with inflow controller type EDL 2 - D. 2...)

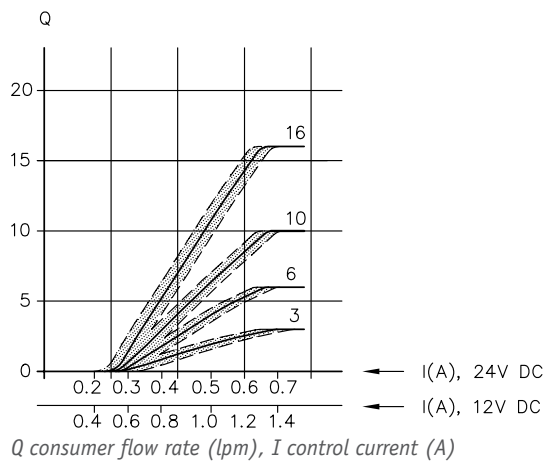
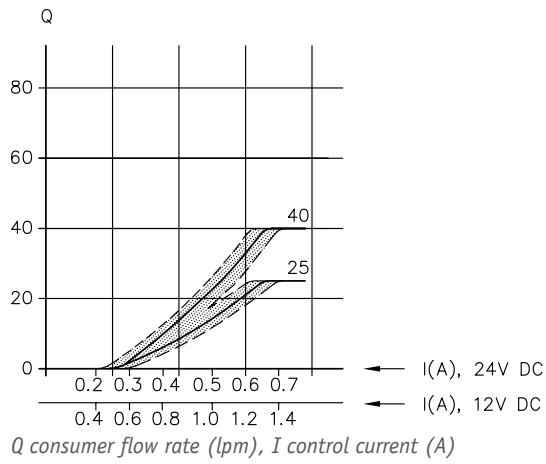

### 3.3 Actuators

#### Actuator E, EI

Solenoid, produced and tested in accordance with DIN VDE 0580  
 Single-action solenoid with anchor chambers sealed on the outside and connected to the return duct. The anchors in the anchor chambers are thereby lubricated by the hydraulic oil and protected against corrosion without the need for maintenance.

Nominal voltage $U_N$	24 V DC	12 V DC
Coil resistance $R_{20}$	22 $\Omega$	5.5 $\Omega$
Current, cold $I_{20}$	1.10 A	2.18 A
Limit current $I_G$ ( $I_{lim}$ )	0.78 A	1.56 A
Power, cold $P_{20} = U_N \times I_{20}$	26 W	26 W
Limit power $P_G = U_N \times I_G$	19 W	19 W
Cut-off energy $W_A$	$\leq 0.3$ Ws	$\leq 0.3$ Ws
Relative duty cycle (reference temperature $\vartheta_{11} = 50^\circ\text{C}$ )	S1	S1
Required dither frequency	40 to 70 Hz (recommended value: 55 Hz)	
Dither amplitude	$20\% \leq A_D \leq 50\%$	

$$A_D(\%) = \frac{I_{Spitze-Spitze}}{I_G} \cdot 100$$

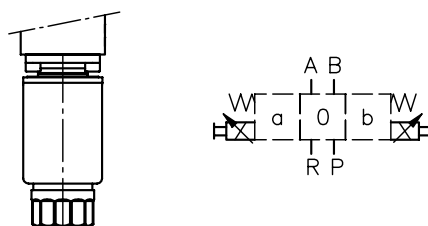

**Characteristics**

Oil viscosity approx. 60 mm<sup>2</sup>/s

I stroke characteristic curve

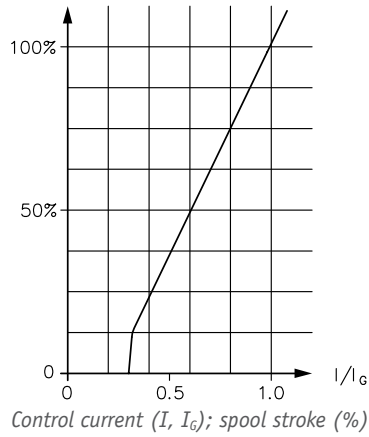

**Electrical connection**

Connection pattern for coding

-X 12, -X 24

DIN EN 175 301-803 A

IP 65 (IEC 60529)

Coil a (1) coil b (2)

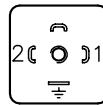
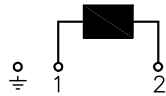

-AMP 12, -AMP 24

-DT 12, -DT 24

AMP Junior Timer

IP 65 (IEC 60529)

IP 67 (IEC 60529)

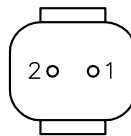
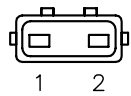

The specifications regarding the IP protection class apply for versions featuring a properly assembled male connector

## 4 Dimensions

All dimensions in mm, subject to change.

### 4.1 Connection blocks

#### Connection blocks

##### PSV 3X.-2

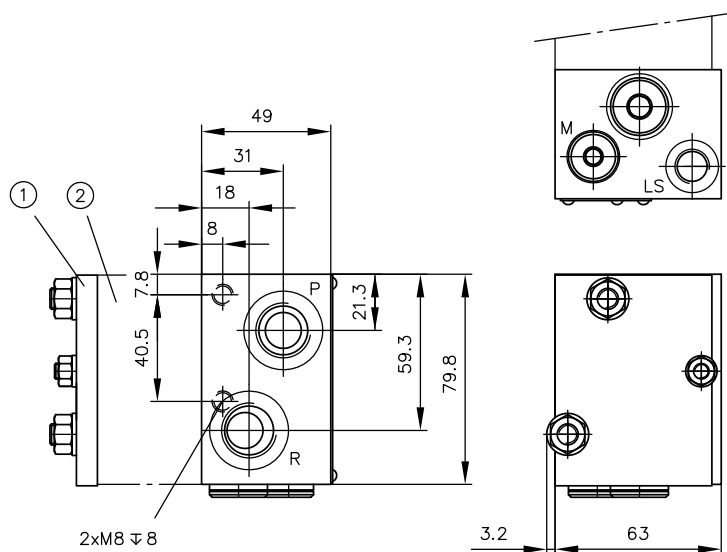

#### Port (ISO 228-1) (BSPP)

P, R	G 1/2
LS, M	G 1/4

##### PSV E0-2

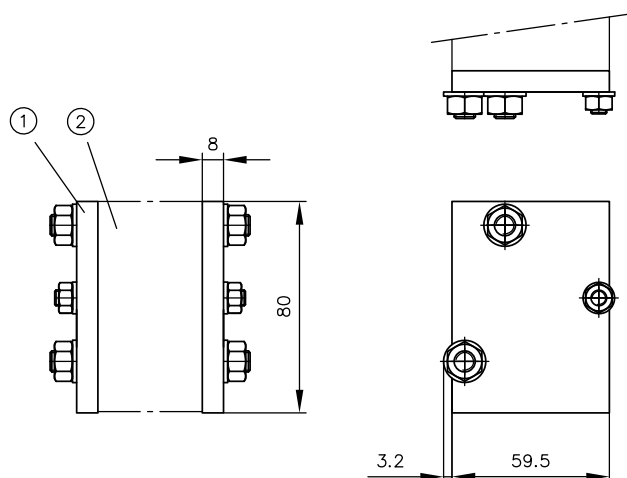

- 1 End plate
- 2 For directional spool valve, see [Chapter 4.2, "Valve sections"](#)

Adapter plates

Coding ZPL 32

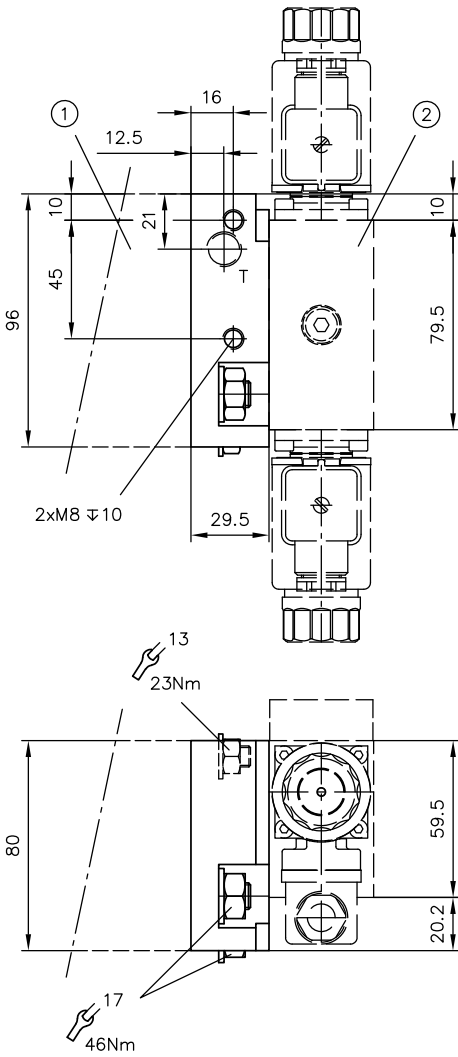

- 1 Add-on spool valves, size 3
- 2 Add-on spool valves, size 2 acc. to [D 7700-2](#)

Coding ZPL 52

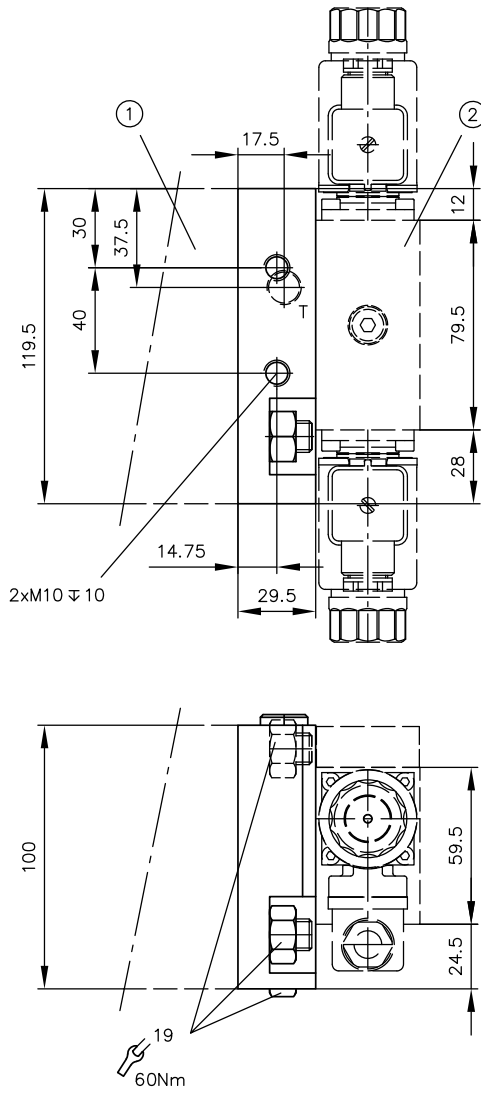

- 1 Add-on spool valves, size 5
- 2 Add-on spool valves, size 2 acc. to [D 7700-2](#)

## 4.2 Valve sections

### Series intermediate plates

Coding **ZPL 22 P6R6**

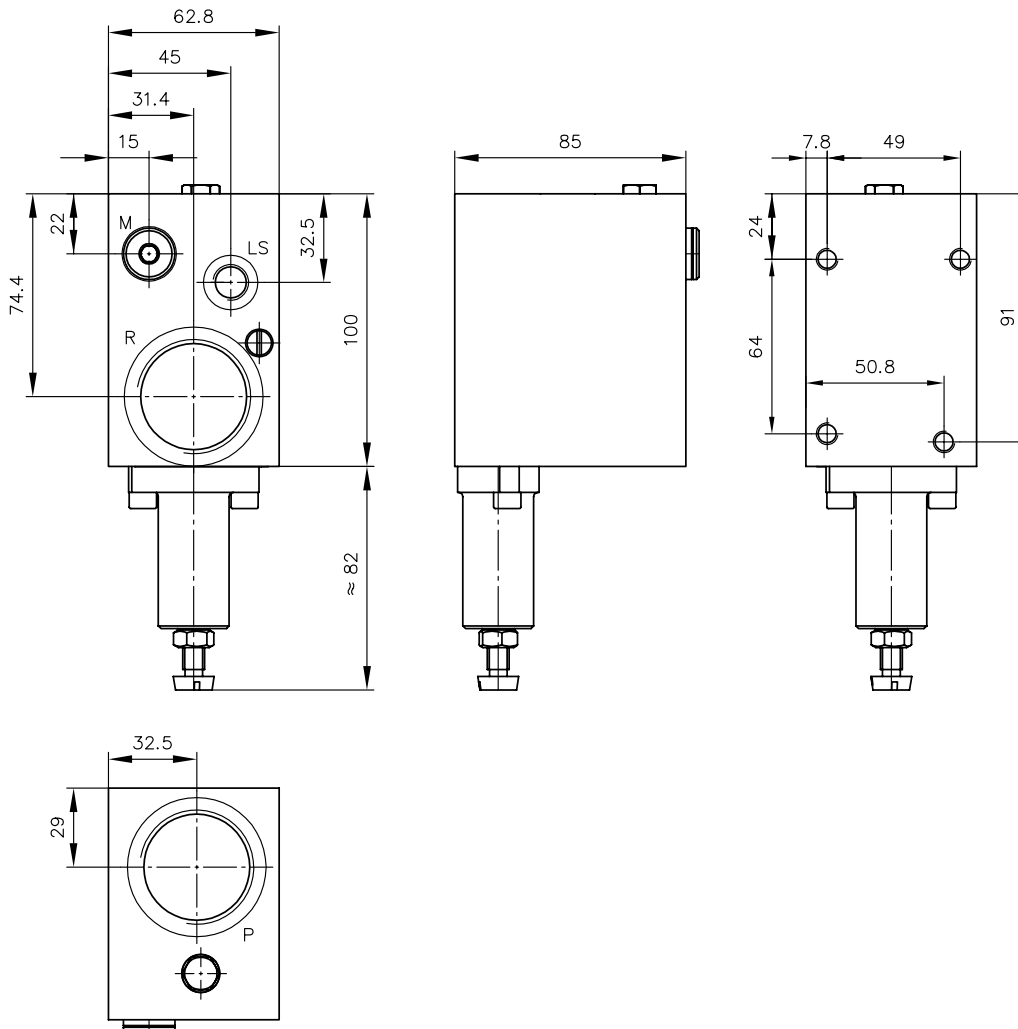

Directional spool valve with actuation E, EI, AEI, BEI

Coding E

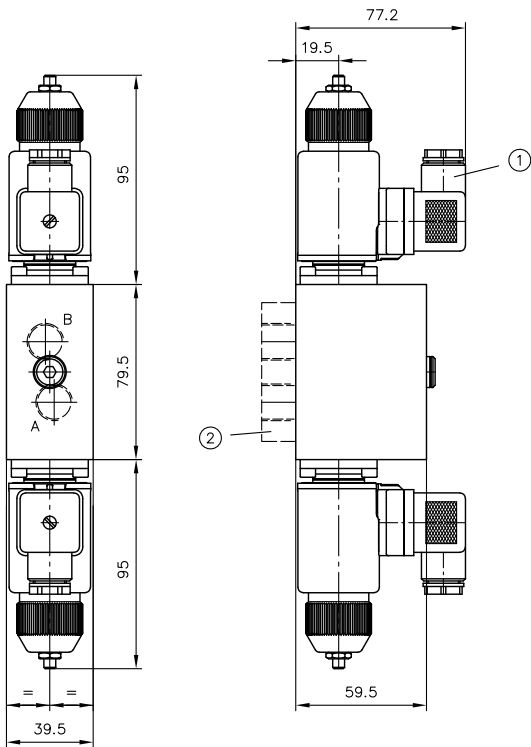

Coding EI

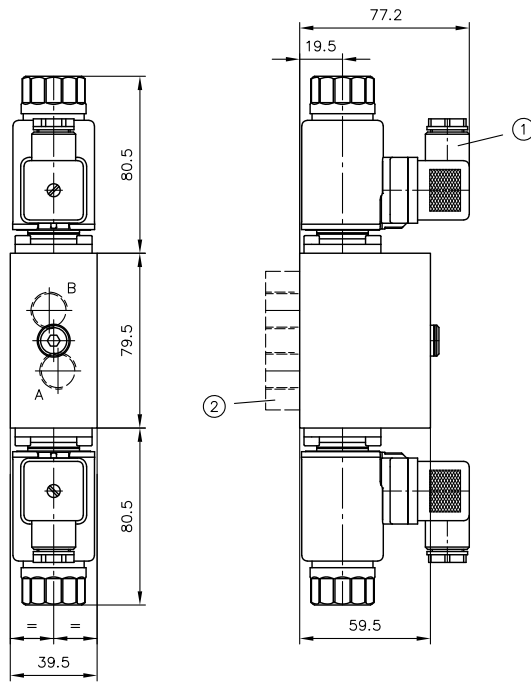

Coding AEI

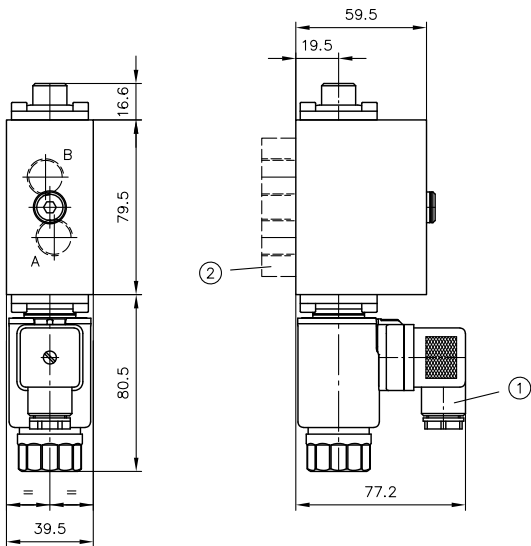

Coding BEI

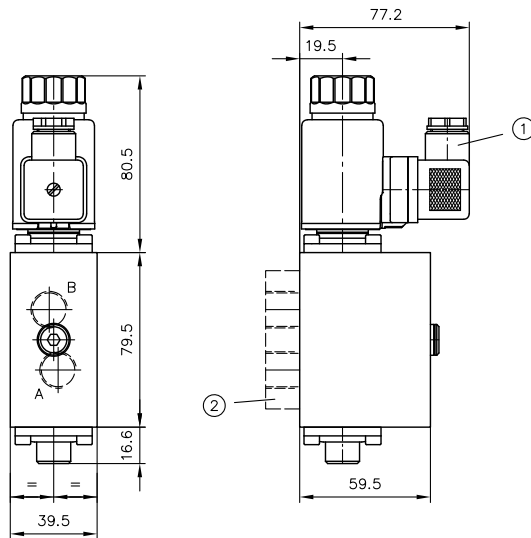

- 1 Male connector can be mounted offset by 180°
- 2 Ancillary blocks



**Additional solenoid versions**

Coding **-AMP 12, -AMP 24**

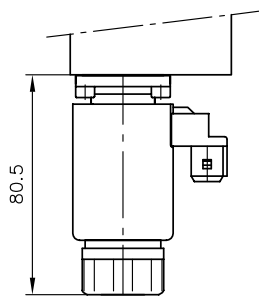

Coding **-DT 12, -DT 24**

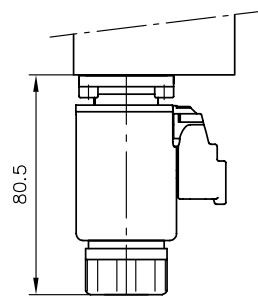

**Directional spool valve with LS pressure limitation and load-signal outlet X**

Coding **C ... X**

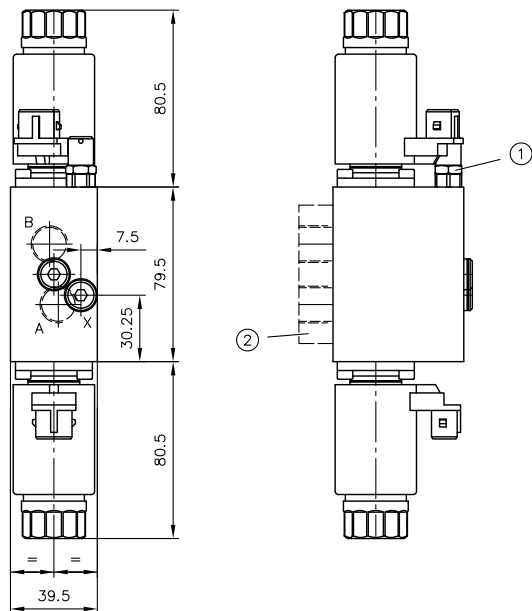

- 1 LS pressure limitation
- 2 Ancillary blocks

Port (ISO 228-1) (BSPP)

X G 1/8

### **5.1 Intended use**

This valve is intended exclusively for hydraulic applications (fluid technology).

The user must observe the safety measures and warnings in this documentation.

**Essential requirements for the product to function correctly and safely:**

- All information in this documentation must be observed. This applies in particular to all safety measures and warnings.
- The product must only be assembled and put into operation by qualified personnel.
- The product must only be operated within the specified technical parameters. The technical parameters are described in detail in this documentation.
- The operating and maintenance manual of the components, assemblies and the specific complete system must also always be observed.

If the product can no longer be operated safely:

1. Remove the product from operation and mark it accordingly.
- ✓ It is then not permitted to continue using or operating the product.

## 5.2 Note regarding assembly, installation and conversion

The product must only be installed in the complete system with standard and compliant connection components (fittings, hoses, pipes, fixtures, etc.).

The hydraulic power pack must be shut down correctly prior to dismantling; this applies in particular to power packs with hydraulic accumulators.



### Danger

**Risk to life caused by sudden movement of the hydraulic drives when dismantled incorrectly!**

Risk of serious injury or death.

- Depressurise the hydraulic system.
- Perform safety measures in preparation for maintenance.

All installation, set-up, maintenance and repairs must be performed by authorised, qualified and trained staff. The use of this product beyond the specified performance limits, operation with non-specified fluids and/or use of non-genuine spares will invalidate the warranty.

### 5.2.1 Mounting

The valve bank must be mounted to the frame or base of the machine in such a way that no stress is induced. Three screws and elastic washers between the bank and the frame are recommended for mounting.

### 5.2.2 Piping

All fittings used must utilise deformable seals. The recommended torque values must not be exceeded.

### 5.2.3 Seal kits

Connection block		DS 7700-21
Valve section		DS 7700-22
Intermediate plate	ZPL 32	DS 7700-22
	ZPL 52	DS 7700-52

## 5.3 Operating instructions

### Product configuration and setting the pressure and flow rate

The statements and technical parameters in this documentation must be strictly observed.  
The instructions for the complete technical system must also always be followed.

#### Note

- Read the documentation carefully before usage.
- The documentation must be accessible to the operating and maintenance staff at all times.
- Keep documentation up to date after every addition or update.



#### Caution

##### **Risk of injury on overloading components due to incorrect pressure settings!**

Risk of minor injury.

- Always monitor the pressure gauge when setting and changing the pressure.

## Purity and filtering of the hydraulic fluid

Fine contamination can significantly impair the function of the hydraulic component. Contamination can cause irreparable damage.

### Examples of fine contamination include:

- Metal chips
- Rubber particles from hoses and seals
- Dirt due to assembly and maintenance
- Mechanical debris
- Chemical ageing of the hydraulic fluid

#### Note

Fresh hydraulic fluid from the drum does not always have the highest degree of purity. Under some circumstances the fresh hydraulic fluid must be filtered before use.

Pay attention to the cleanliness level of the hydraulic fluid in order to maintain faultless operation.

(Also see cleanliness level in [Chapter 3, "Parameters"](#).)

(also see cleanliness level in

## 5.4 Maintenance information

This product is largely maintenance-free.

Conduct a visual inspection at regular intervals, but at least once per year, to check if the hydraulic connections are damaged. If external leakages are found, shut down and repair the system.

Clean the device surface of dust deposits and dirt at regular intervals, but at least once per year.

## 6 Other information

### 6.1 Notes for selection and lay-out

#### a) Connection block

- Additional damping options for the connection blocks type PSL and PSV are described in the D 7700 ++ publications.

#### b) Control blocks

##### Marking 2 (example EDL 2-DA 2 L 25/16...)

- The standard version of the load-compensated directional spool valve is fitted with an inflow controller (marking 2). Thanks to the control pressure (approx. 5 bar), the consumer flow rate is regulated depending on the spool valve elevation (spool valve edges are designed as metering orifices) regardless of the system pressure and other consumers:

$$Q \approx A_{\text{Schieber}} \cdot \sqrt{\Delta p_{\text{Regler}}}$$

##### Marking 7 (example EDL 2-DA 7 H 40/40...)

- If the control pressure is changed, the maximum possible flow rate of the individual consumer may be influenced (see statements on marking 2 above). The control pressure is approx. 9 bar for marking 7. This results in a nominal flow rate that is approx. 1.3 times higher than for directional spool valve variants with marking 2 (standard).

##### Marking DAR 2 and DAR 7

- In addition to its control function, the pressure compensator also acts as a check valve. This prevents a possible flow direction reversal in the event of a shortage in supply on the pump side.

#### c) Use of variable pumps

- For load-sensing controls in combination with variable pumps, the LS signal duct to the (load-sensing controller) of the pump is limited to minimise circulation losses when in neutral position (i.e. when no hydraulic oil is dispensed to the consumers). This limiting takes place via the proportional directional spool valves. Without this limiting, the pump would have to work in the no-lift position with its remaining delivery flow against the maximum pressure setting of the pressure controller. As there are directional spool valves without this limiting possibility, some brands of (load-sensing controllers) have an internal bypass orifice from the LS signal inlet to a decompressed leakage outlet. Thanks to the internal limiting of proportional directional spool valves of type EDL, this bypass channel is not necessary and it can even cause malfunctions due to lost control oil. For functional reasons, the control oil flow must be consciously limited (approx. 2 lpm) (creeping of the consumer).



#### Note

Care must be taken to ensure that a possible bypass orifice in the pressure delivery flow controller is sealed.

**d) Combination with load-holding valves**

- If three control elements, the 3-way controller in the pump or in the connection block, the 2-way controller in the directional valve and load-holding valve insert are connected in series, oscillations may occur due to external load alternations and resonance effects. These effects can be effectively suppressed by systematic use of a bypass orifice and a throttle, check, pre-load valve combination connected in parallel within the control oil system at the load-holding valve type LHDV acc. to [D 7770](#). Similar behaviour can be achieved using load-holding valves of type LHT acc. to [D 7918](#).

**e) Combination of more than 10 directional spool valves**

- By switching the load-sensing line in series, a total of max. 10 directional spool valves can be linked. If more than 10 directional spool valves are required, these must be arranged in separate valve banks.

**f) Additional components****For electrical actuations**

- [Line connector type MSD and others: D 7163](#) (Line connector MSD 3-309 is included in scope of delivery for coding G 12 and G 24)
- [Proportional amplifier type EV22K5: D 7817/2](#)
- [Proportional amplifier type EV1M3: D 7831/2](#)
- [Proportional amplifier type EV1D: D 7831 D](#)
- [Proportional amplifier type EV2S: D 7818/1](#)
- [CAN node type CAN-IO: D 7845-IO 14](#)
- Programmable logic valve control PLVC 8 according to D 7845-2
- [Joystick type EJ: D 7844](#)

Radio controls are accepted if they fulfil the requirements acc. to Sk 7814

(Approved brands: HBC-ELEKTRONIK, D-74564 Crailsheim; HETRONIK Steuer-Systeme, D-84085 Langquaid; NBB-Nachrichtentechnik, D-75248 Ölbronn-Dürrn; SCANRECO Industrieelektronik AB, S-5227 Södertälje, HATOX, D-75217 Birkenfeld)

**Load-holding valves**

- [Load-holding valve type LHT: D 7918](#)
- [Load-holding valve type LHDV: D 7770](#)
- [Load-holding valve type CLHV - Cartridge: D 7918-VI-C](#)

**Other valves**

- [Proportional directional spool valve, type PSL and PSV size 2: D 7700-2](#) (can be combined with EDL 2 without intermediate plate)
- [Proportional directional spool valve, type PSL, PSM and PSV size 3: D 7700-3](#) (can be combined with EDL 2 using intermediate plate ZPL 32)
- [Proportional directional spool valve, type PSL, PSM and PSV size 5: D 7700-5](#) (can be combined with EDL 2 using intermediate plate ZPL)
- [Proportional directional spool valve type PSLF, PSVF and SLF size 3: D 7700-3F](#) (directional spool valve in flange design)
- [Proportional directional spool valve type PSLF, PSVF and SLF size 5: D 7700-5F](#) (directional spool valve in flange design)
- [Connection block type HMPL and HMPV for proportional directional spool valve: D 7700 H](#)

## 6.2 Circuit examples

Order coding example 1: PSL control for hydraulic oil supply via constant pump

PSL 3 U/250 - 2	- DA 2	L	40/25	/E	/2 AN200 BN200	- E0 - DT 24
	- DA 2	L	25/16 C 150 X	/E	/2 AN250 BN250	
	- DA 2	H	40/40 W 3	/E	/2	

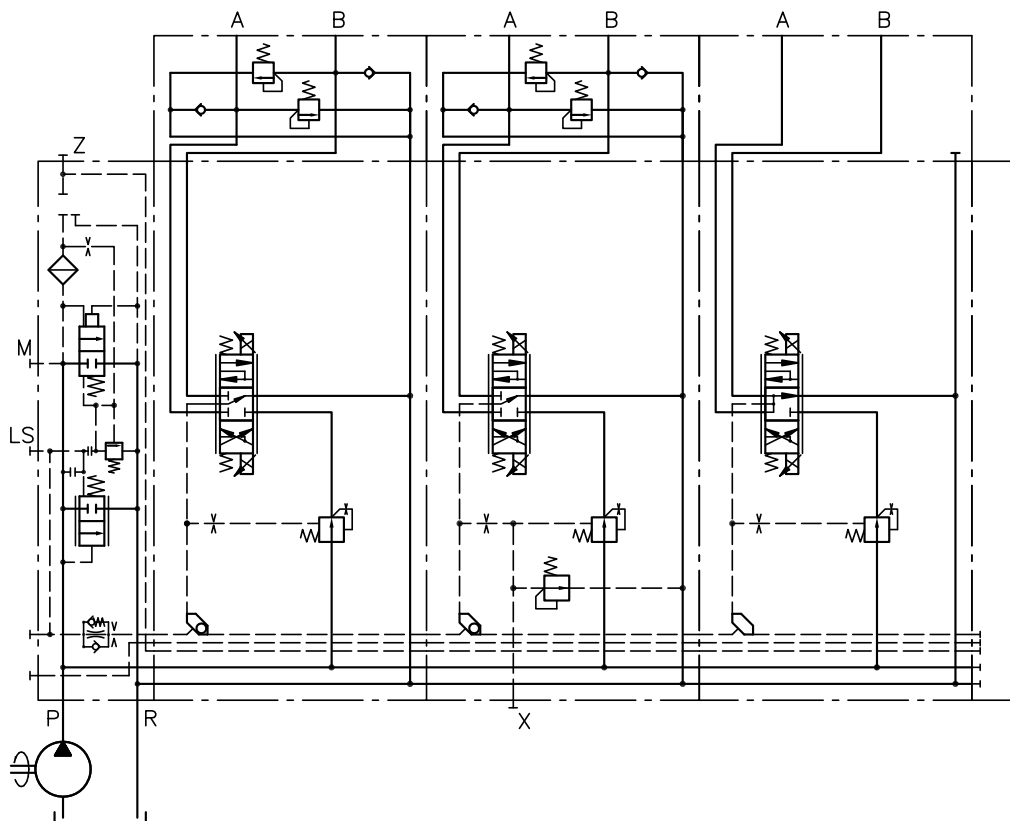

Order coding example 2: PSV control for hydraulic oil supply via variable pump

PSV 551/300 - 3	- 32	0	80/80	C200	/EI		
	- ZPL 32						
	- A 2	J	40/25	A200 B150	/EI	/2	
	- DA 2	L	25/16		/EI	/2	
	- DA 2	L	25/16		/EI	/2	- E1 - AMP 24 K 4

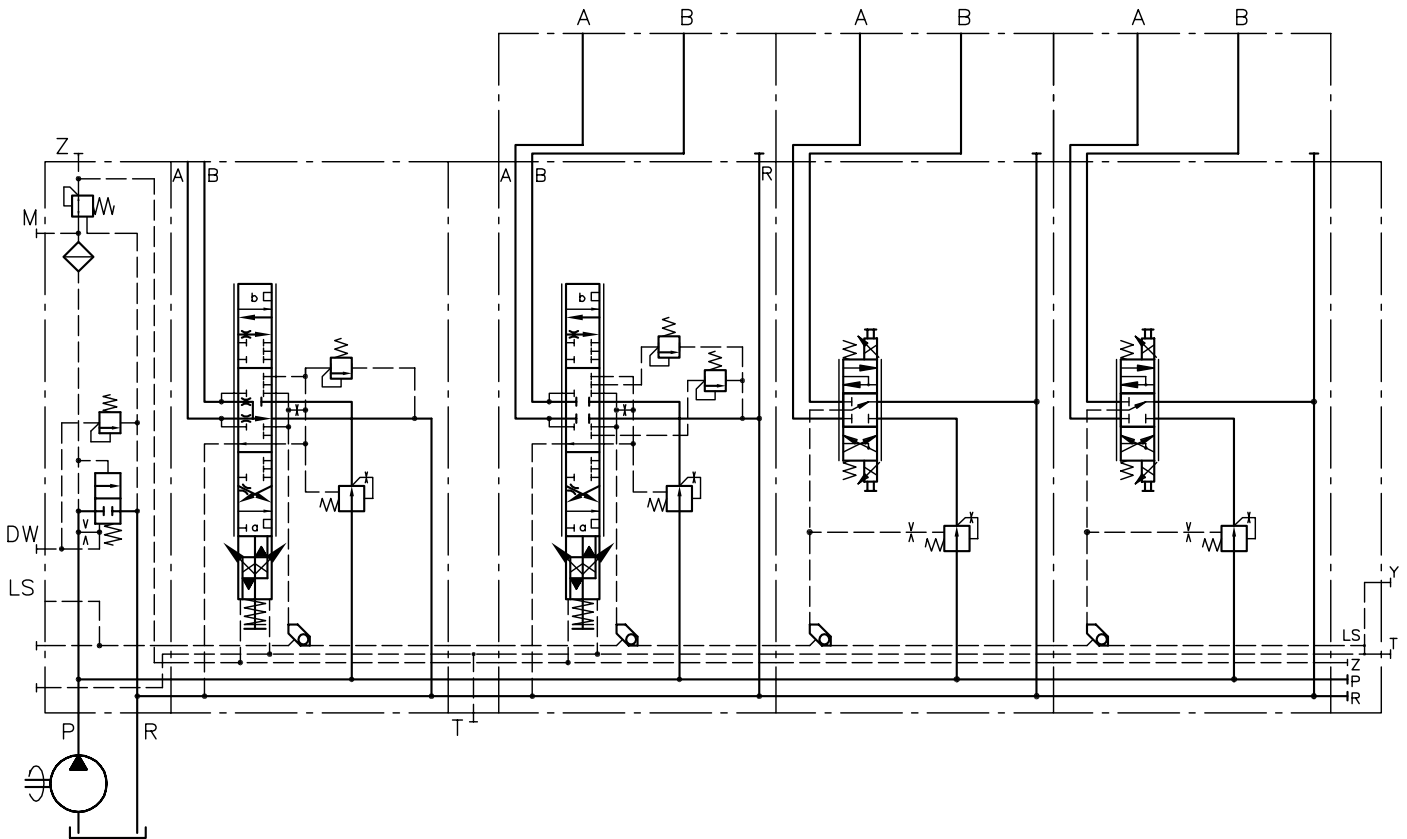



**Order coding example 3: PSV control for hydraulic oil supply via variable pump**

PSV E0 - 2	- DA 2	H	50/50	/EI	/2 AS180 BS100	- E0 - AMP 24
	- DA 2	H	25/25	/EI	/2 AS200 BS200	
	- ZPL 22 P6R6/250					
	- DA 2	L	16/10	/EI	/2	
	- DA 2	L	6/3	/EI	/2	

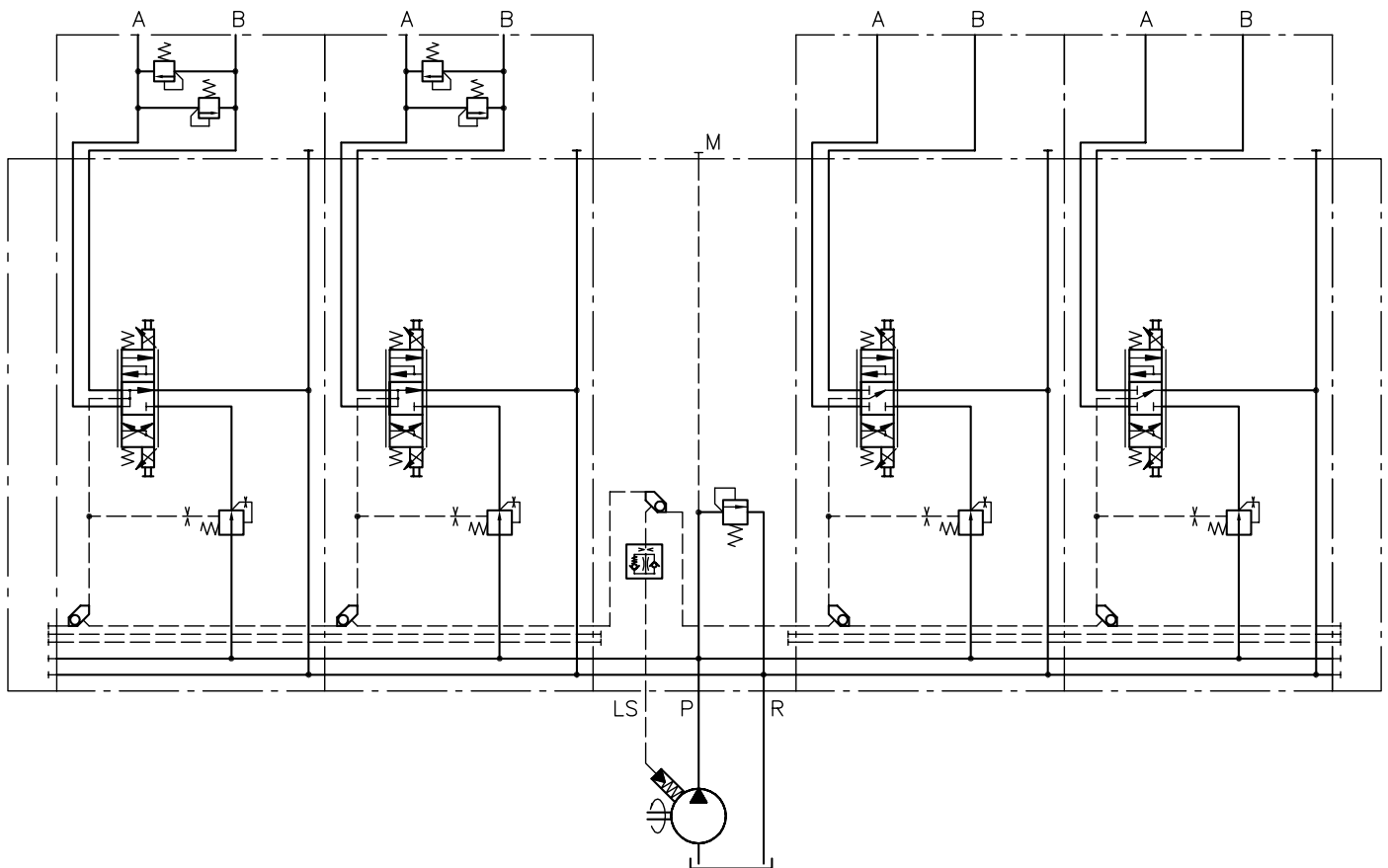

## Further information

### Additional versions

- Proportional directional spool valve, type PSL and PSV size 2: D 7700-2
- Proportional directional spool valve, type PSL, PSM and PSV size 3: D 7700-3
- Proportional directional spool valve, type PSL, PSM and PSV size 5: D 7700-5
- Proportional directional spool valve type PSLF, PSVF and SLF size 3: D 7700-3F
- Proportional directional spool valve type PSLF, PSVF and SLF size 5: D 7700-5F
- Proportional directional spool valve banks type PSLF and PSVF size 7: D 7700-7F
- Directional spool valve bank type SWS: D 7951
- Directional spool valve banks type CWS 2: D 7951 CWS